

International Journal of Engineering Sciences & Research Technology

(A Peer Reviewed Online Journal)
Impact Factor: 5.164



Chief Editor

Dr. J.B. Helonde

Executive Editor

Mr. Somil Mayur Shah

ABSTRACT

Robot change the way of life of human beings. It makes life easier in assisting human in his daily activities. Forward and reverse manipulator can be used in treating patients in hospitals. Technology provides techniques which to be used in help human body control system through inventing the mechanical support in the interaction of body movement. The paper works only on the programmable controller of the robot arm for human rehabilitation and it programmed in MATLAB Programmer, therefore, the result of the simulation shows how the arms joint actuated in forward or reverse kinematics system.

KEYWORDS: Robot, Interaction, Kinematic, programmed controller and Human arms joint.

1. INTRODUCTION

Robot Institute of America “*robot as a reprogrammable versatile manipulator invented to move and control materials, quantities, apparatuses, through variable programmed motions for the performance of a multiples tasks*” Mark W. Spong, Seth Hutchinson, and M. Vidyasagar, 2010 “Robot Modeling and Control”. In the development of robot for rehabilitation, robot becomes one of the physical achievement that can ease and assist in the fracture treatment and other orthopedics treatment in hospital. Robot arm can help the patients to move their arm joint in forward or reverse directions. But this can only be achieved through the design and implementation of programmed controller and mechanical kinematic structure.

Robot is not just a mechanical arm there are so many components that associated in the buildup of the robot. The components of robot include source of input (power), programmed controller and mechanical arm. Mechanical arm is six degree of freedom or less and are kinematically classified into three arm joints and wrist been described independently. The programmed designed to control the mechanical arms to be in motion is implemented in MATLAB while the result of the simulation is expected to show how the arms will actuate in forward or reverse form.

The human and robot interaction control of rehabilitation with elastic actuators reduce the problem concerning the joint of the arms in treating the patient in the hospitals. Haoyong Yu (2015) invented the robot which can control the knee joint and can even sense the human interaction with gait and brain information for his safety is a critical concern to avoid any dislocation of the fracture and help to move the arm without discomfort feelings. The robot has four components as knee module, actuator, ankle module and dc motor. Dc motor is powered the actuator, two linear compression spring are place in both side and one compressor can be extended to knee module.

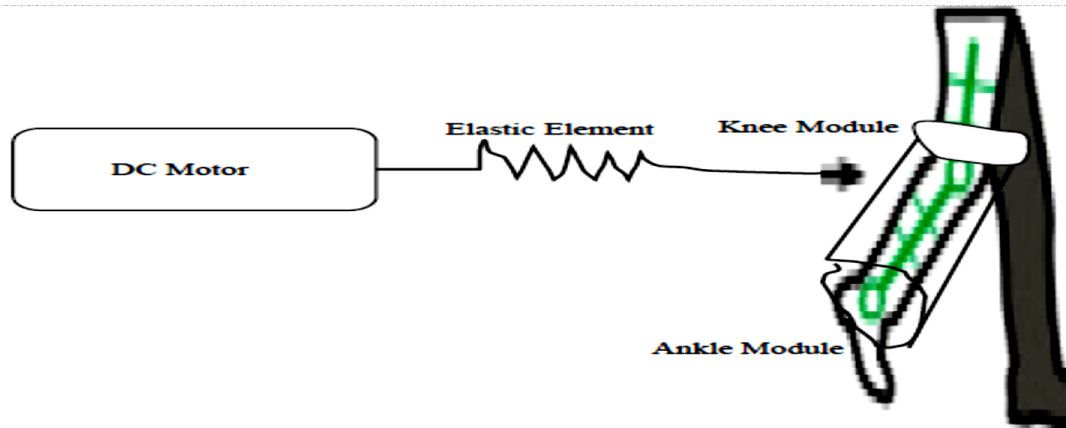

Figure 1: Wearable Human-Robot Interaction for Rehabilitation with Elastic Actuator

The above Figure 1 shows the human interaction with robot to help in rehabilitation of knee to joint in the hospitals.

2. CONTROLS OPERATION

As stated earlier robot has six degree of freedom or less. The degree of freedom depends on the number of links and joints of the mechanical arm structure. Let the robot has two link and joint as shown in figure 2. and the arm joint to be rotate or translate either in forward or reverse kinematic form.

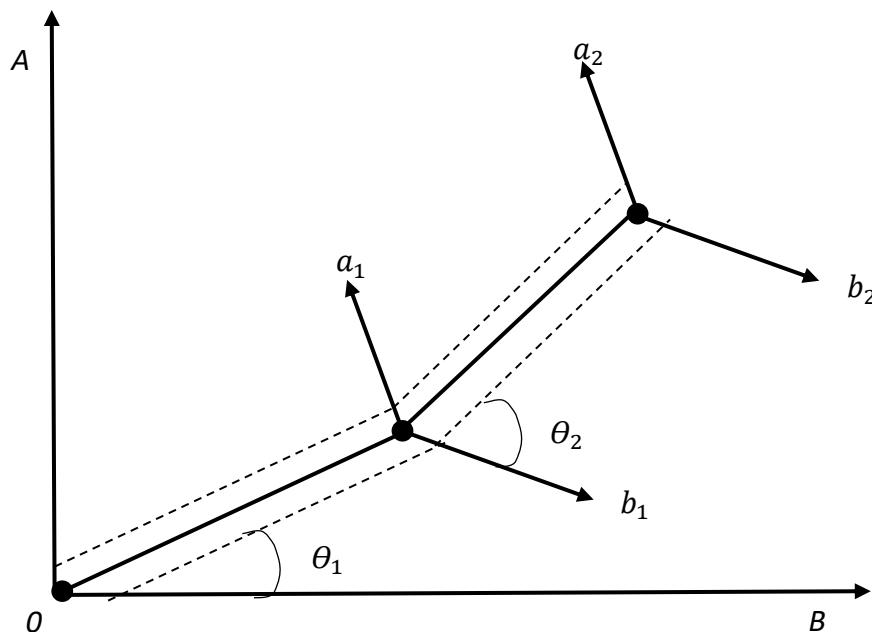

Figure 2: Two Link Arm Robot

Let assume the above coordinate frames of two link arm robot move in forward kinematic. Mathematical expression of the coordinate A and B at the end module can be represent as;

$$A = a_2 \sin(\theta_1 + \theta_2) + d_1 \sin \theta_1$$

$$B = a_2 \cos(\theta_1 + \theta_2) + d_1 \cos \theta_1$$

Where by d_1 and d_2 are the lengths of two links arm. The base of two links arm is in the direction cosines of the end module (a_2 and b_2 axis) which relate to A and B axis and can be written independently as;

$$a_2 \cdot A = \cos(\theta_1 + \theta_2)$$

$$a_2 \cdot B = -\sin(\theta_1 + \theta_2)$$

$$b_2.A = \sin(\theta_1 + \theta_2)$$

$$b_2.B = \cos(\theta_1 + \theta_2)$$

The above equations can be combine into a positioning matrix as;

$$\begin{bmatrix} a_2.A & b_2.A \\ a_2.B & b_2.B \end{bmatrix} \begin{bmatrix} \cos(\theta_1 + \theta_2) & \sin(\theta_1 + \theta_2) \\ -\sin(\theta_1 + \theta_2) & \cos(\theta_1 + \theta_2) \end{bmatrix}$$

The above positioning matrix define that the two link joint arm operate in forward kinematic. Let consider the arm joint actuate in reverse kinematic form given the joint angles $\theta_1 + \theta_2$, the end module can be determine from the coordinates.

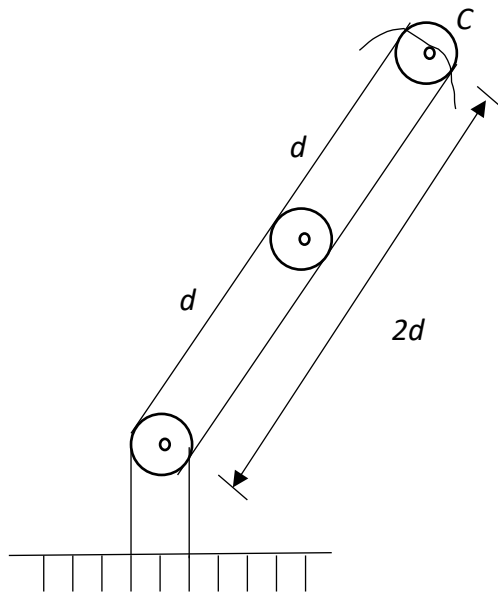

Figure 3.0: The Reverse Kinematic Structure

The reverse kinematic expression is nonlinear, therefore, the solution can be null or may not have unique solution. The reverse kinematic structure of robot arms can be representing in vector diagram as shown in the figure 4.

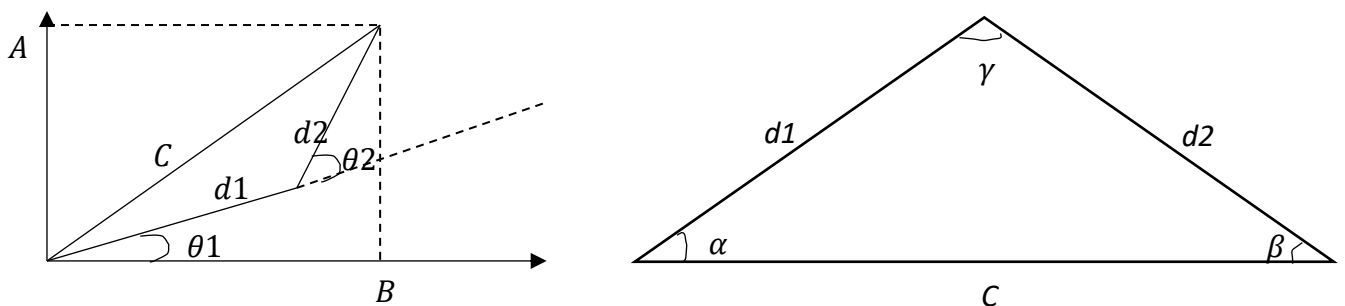

Figure 4: Vector Diagram of Reverse Kinematic System

Using cosine rule the diagonal line C will be given as;

$$C^2 = d_1^2 + d_2^2 - 2d_1d_2\cos\theta$$

The gamma γ is the angle corresponding to C or γ can be substituted with θ as;

$$\cos\theta = -\cos(180^\circ - \theta)$$

$$\sin\theta = \sin(180^\circ - \theta)$$

$$C^2 = A^2 + B^2$$

Therefore $\cos\theta_2$ can giving as;

$$\cos\theta_2 = \frac{A^2 + B^2 - d_1^2 - d_2^2}{2d_1d_2}$$

$$\theta_2 = \cos^{-1}\left(\frac{A^2 + B^2 - d_1^2 - d_2^2}{2d_1d_2}\right)$$

Recalled that from the trigonometric rules;

$$\sin^2\theta_2 + \cos^2\theta_2 = 1$$

$$\sin^2\theta_2 = 1 - \cos^2\theta_2$$

$$\sin\theta_2 = \sqrt{1 - \cos^2\theta_2}$$

$\cos\theta_2$ can be repaced with $\cos^2\theta_2$ to find the $\sin\theta_2$

$\sin\theta_2$ can give as;

$$\sin\theta_2 = \sqrt{1 - \left(\frac{A^2+B^2-d_1^2-d_2^2}{2d_1d_2}\right)^2}$$

$$\theta_2 = \sin^{-1}\sqrt{1 - \left(\frac{A^2+B^2-d_1^2-d_2^2}{2d_1d_2}\right)^2}$$

$\tan\theta_2$ can give as,

$$\tan\theta_2 = \frac{\sin\theta_2}{\cos\theta_2}$$

$$\tan\theta_2 = \frac{\sqrt{1 - \left(\frac{A^2+B^2-d_1^2-d_2^2}{2d_1d_2}\right)^2}}{\frac{A^2+B^2-d_1^2-d_2^2}{2d_1d_2}}$$

$$\theta_2 = \tan^{-1}\sqrt{\frac{1 - \left(\frac{A^2+B^2-d_1^2-d_2^2}{2d_1d_2}\right)^2}{\frac{A^2+B^2-d_1^2-d_2^2}{2d_1d_2}}}$$

Therefore, θ_1 can be expressed as;

$$\theta_1 = \tan^{-1}\left(\frac{A}{B}\right) - \tan^{-1}\left(\frac{d_1 + d_2\cos\theta_2}{d_2\sin\theta_2}\right)$$

The arm joint can rotate in three directions as shown in figure 5.0 coordinate frame of the robot. Let the arm joint rotate in right and left hand side as in the coordinate frame in the direction of a_0 and b_0 at a fixed point c_0 . the rotational transformation can be formed as a_1 , b_1 , and c_1 .

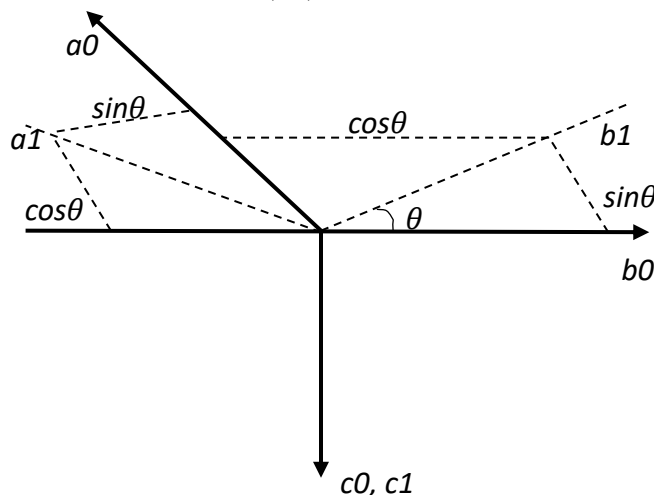

Figure 5: Co-ordinate Frame of Robot Arm Joint

In the above coordinate frame, the following properties can be obtaining as;

- a_1 is in the direction of $a_0 = \sin\theta$
- a_1 is in the direction of $b_0 = \cos\theta$
- a_1 is in the direction of $c_0 = \cos\theta$
- b_1 is in the direction of $a_0 = -\sin\theta$
- b_1 is in the direction of $b_0 = \cos\theta$
- b_1 is in the direction of $c_0 = \cos\theta$
- c_1 is in the direction of $a_0 = \sin\theta$
- c_1 is in the direction of $b_0 = \cos\theta$
- c_1 is in the direction of $c_0 = \sin\theta$

The above expression can be formed as rotational transformation matrix as,

$$R^T = \begin{bmatrix} a_1 \cdot a_0 & b_1 \cdot a_0 & c_1 \cdot a_0 \\ a_1 \cdot b_0 & b_1 \cdot b_0 & c_1 \cdot b_0 \\ a_1 \cdot c_0 & b_1 \cdot c_0 & c_1 \cdot c_0 \end{bmatrix} = \begin{bmatrix} \sin\theta & -\sin\theta & \sin\theta \\ \cos\theta & \cos\theta & \cos\theta \\ \cos\theta & \cos\theta & \sin\theta \end{bmatrix}$$

The robot is designed in such a way that it has two links with joint at the center and two end modules as shown figure 6. The two end module will be wear in the wrist of human arm or knee arm to ankle of the leg. It is wearable robot which can be used in hospital to help patient in fracture rehabilitation.

3. ROTATIONAL TRANSFORMATION

The max rotation of $\theta \leq 135$, therefore at initial stage the $\theta = 0$ which cause the translational transformation. Before taking step the leg is at 90° and $\cos\theta = 0$ and $\sin\theta = -1$ at rotation around c-axis

The rotational transformation matrix around c-axis is;

$$R_c^T = \begin{bmatrix} \cos\theta & -\sin\theta & 0 \\ \sin\theta & \cos\theta & 0 \\ 0 & 0 & 1 \end{bmatrix}$$

The inverse rotation is equal to rotational transformation that is the determinant of rotational matrix is 1.

$$c_0 \cdot c_1 = 1$$

The rotational transformation matrix around a-axis is;

$$R_a^T = \begin{bmatrix} 1 & 0 & 0 \\ 0 & \cos\theta & -\sin\theta \\ 0 & \sin\theta & \cos\theta \end{bmatrix}$$

The inverse rotation is equal to rotational transformation that is the determinant of rotational matrix is 1.

$$a_0 \cdot a_1 = 1$$

The rotational transformation matrix around b-axis is;

$$R_b^T = \begin{bmatrix} \cos\theta & 0 & \sin\theta \\ 0 & 1 & 0 \\ -\sin\theta & 0 & \cos\theta \end{bmatrix}$$

The inverse rotation is equal to rotational transformation that is the determinant of rotational matrix is 1.

$$b_0 \cdot b_1 = 1$$

The translational transformation about c-axis when is $\theta = 0$ is given by;

$$R_c = \begin{bmatrix} \cos 0 & -\sin 0 & \sin 0 \\ \sin 0 & \cos 0 & \sin 0 \\ \sin 0 & \sin 0 & \cos 0 \end{bmatrix} = \begin{bmatrix} 1 & 0 & 0 \\ 0 & 1 & 0 \\ 0 & 0 & 1 \end{bmatrix}$$

Simulation results shows that the robots' arm joint is actuating in forward and reverse form. Its two links arm with joint at center and it has two end module, whenever the joint or end module sense motion from the human body the robot will actuate which helps in fractures to be stable and will not cause discomfort feelings.

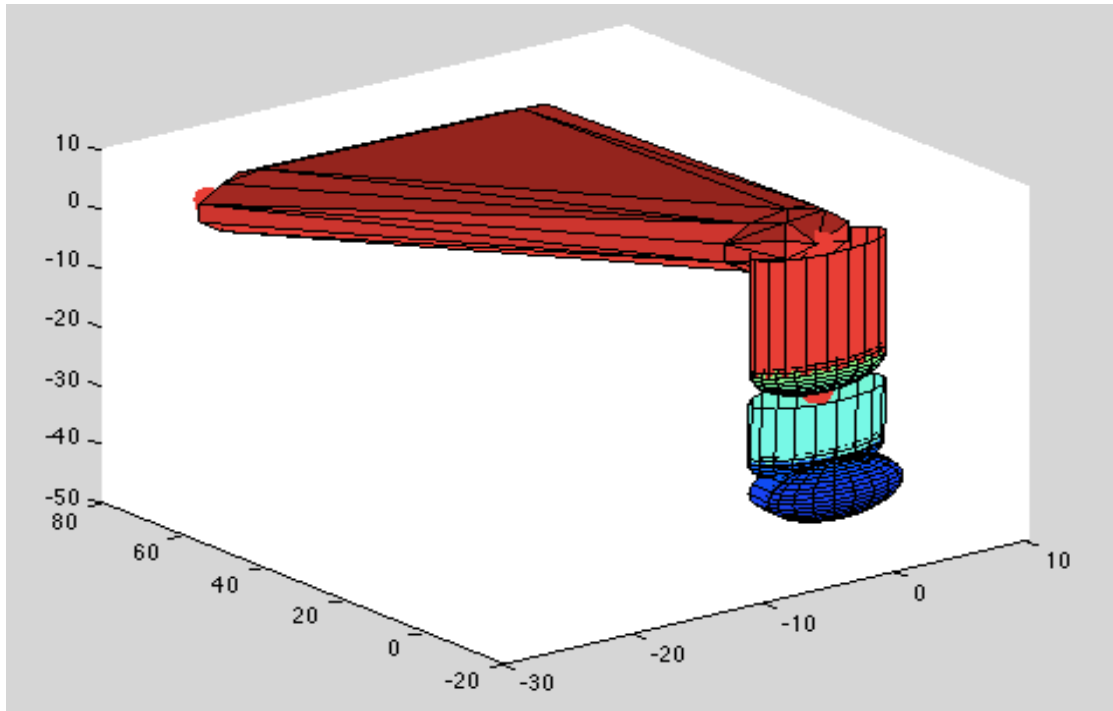

Figure 6.0: Robot Arm Kinematic Structure

Robot arm can work in hospitals for fracture treatment and help the patient to move his arm and joint without causing dislocation of the injury. The idea here is to design the programmed controller which will control the kinematic structure of the robot. The kinematic structure can be recommended to be design and been implemented. The structure has to be in five segments which composes the wrist of the two links, two end module, joint, elastic actuator and dc motor that will rotate the joint.

4. CONCLUSION

Robot arm programmable controller is the fundamental segment in controlling the robot to actuate in forward and reverse form. The robot programmed controller is design to control the robot in rehabilitation of human arm or ankle to knee joint of human leg which to be actuate without the patent feel the pain or cause the fracture dislocation. The programmed where designed in MATLAB and the experimental results have confirmed that the programmed controller work successfully.

REFERENCES

- [1] Dragomir N. Nenchev, Teppei Tsujita, "Forward Kinematic Solution" In Humanoid Robots Modeling and Control, 2019, pp 15-82
- [2] Haoyong Yu, Sunan huang, Gong Chen, "Human Robot Interaction Control of Rehabilitation Robots with Series Elastic Actuator", IEEE Transactions on Robotics, Volume: 31 Issue: 5. 2015.
- [3] Mark W. Spong, Seth Hutchinson, and M. Vidyasagar, "Robot Modeling and Control", Published, JOHN WILEY & SONS, INC., New York, pp. 1-200, 2010.
- [4] C.H. Su and C. W. Radcliffe. Kinematics and Mechanisms Design. Wiley, New York, 1978.
- [5] D. E. Whitney. The mathematics of coordinated control of prosthetic arms and manipulators. J. Dyn. Sys., Meas. Cont., December 1972.
- [6] K. Kong, J. Bae, and M. Tomizuka, "A compact rotary series elastic actuator for human assistive systems," IEEE/ASME Trans. Mechatronics, vol. 17, no. 2, pp. 288–297, Apr. 2012.



- [7] H. Yu, M. Spenko, and S. Dubowsky, "An adaptive shared control system for an intelligent mobility aid for the elderly," *Auton. Robot.*, vol. 15, pp. 53–66, 2003.
- [8] C. Zhu, M. Oda, H. Yu, H. Watanabe, and Y. Yan, "Walking support and power assistance of a wheelchair typed omnidirectional mobile robot with admittance control," in *Mobile Robots—Current Trends*, Z. Gacovski, Ed. Rijeka, Croatia: InTech, 2011.
- [9] Y. Stauffer, Y. Allemand, M. Bouri, J. Fournier, R. Clavel, P. Metrailler, R. Brodard, and F. Reynard, "The Walk Trainer—A new generation of walking re-education device combining orthoses and muscle stimulation," *IEEE Trans. Neural Syst. Rehabil. Eng.*, vol. 17, no. 1, pp. 38–45, Feb. 2009.
- [10] S. Jezernik, G. Colombo, T. Keller, H. Frueh, and M. Morari, "Robotic orthosis lokomat: A rehabilitation and research tool," *Neuromodulation: Technol. Neural Interface*, vol. 6, pp. 108–115, 2003.
- [11] A. M. Dollar and H. Herr, "Lower extremity exoskeletons and active orthoses: Challenges and state-of-the-art," *IEEE Trans. Robot.*, vol. 24, no. 1, pp. 144–158, Feb. 2008.

